

## DEVELOPMENT OF METHODS FOR REDUCING THE VOLUME OF ASPIRATION DURING OVERLOADS OF GRANULAR MATERIALS

O. A. AVERKOVA\*, I.N. LOGACHEV\*, K.I. LOGACHEV\*, E.I. TOLMACHEVA\*,  
V.A. UVAROV\*

\* Belgorod State Technological University named after V.G. Shukhov  
(BSTU named after V.G. Shukhov), 308012 Belgorod, Russia, Kostukova str., 46  
e-mail: averkova.oa@bstu.ru, web page: <http://www.bstu.ru>

**Key words:** Aspiration, bulk material transfer, air suction.

**Abstract.** The schemes of aspiration of elevator overloads have been developing. Balance equations of ventilation of aspiration covers are compiled. The system of equations for determination of the volumes of ventilating air for a standard node overload are formulated and solved. Ways of reducing productivity of aspiration systems are offered and analytically substantiated.

Three bypass channels can be used to reduce aspiration volumes in elevator handling facilities by maintaining a smaller negative pressure inside unaspirated cowls of the elevator feeder and head. Airflows can be quantitatively decomposed using combined equations describing pressure losses in loops of a proposed aerodynamic equivalent for the assembly. These combined non-linear equations have been solved numerically using a specially developed algorithm based upon joint application of iterative and bisection procedures.

Analysis of the findings for a “standard” elevator indicates that reduction in flow rates of air entering through leakage areas of unaspirated cowls is maximized when two bypass connections are installed: the lower one, connecting feeder cowl with a buffer chamber upstream of elevator boot cowl, and the upper one, connecting elevator head cowl with the inner chamber of a double-walled cowl of the upper (receiving) conveyor. The total flow rate in the case reviewed was 1.37 times lower than (a corresponding aspiration case with identical process and design parameters of the assembly, but with no bypass ducts). The effect cited may differ from the actual effect in every particular case. The computer program developed for the purpose can be used to provide a design-stage estimate.

### 1 INTRODUCTION

Relevant problems in the design of aspiration cowl for loose-matter handling facilities include devising means and techniques for reducing aspiration volumes necessary to maintain proper dedusting efficiency as well as reducing the carryover of dustlike material into the aspiration network.

In order to reduce the volume of air ejected by a flow of loose matter, the most rational and rewarding approach would be to ensure closed-loop circulation of dust-laden air streams in transfer chutes without using any additional forced-draft devices. Air circulation processes in

such chutes have not been described analytically to this day.

This paper completes a series of papers [1-5].

## 2 REDUCING REQUIRED ASPIRATION VOLUMES IN BYPASSED ELEVATOR HANDLING SYSTEMS

Let's now move on to examine regularities in cross-flows of air given a more complicated case, using three bypass ducts for an aspirated elevator handling facility (Fig. 1). In particular we'll be studying the behavior of flow rates  $Q_5, Q_8$  and  $\Delta Q = Q_2 - Q_1$ .

For this purpose we'll put together obvious equations of air dynamics and balance for ducts and flow junction points.

$$P_s - P_{bc} + P_2(Q_2) = R_2 Q_2^2; \quad (1)$$

$$P_{bc} - P_s + P_1(Q_1) = R_1 Q_1^2; \quad (2)$$

$$P_s - P_y + P_3(Q_3) = R_3 Q_3^2; \quad (3)$$

$$P_y - P_c = R_8 Q_8^2; \quad (4)$$

$$P_y - P_s = R_7 Q_7^2; \quad (5)$$

$$P_d - P_{bc} + P_0(Q_0) = R_0 Q_0^2; \quad (6)$$

$$P_{bc} - P_d = R_4 Q_4^2; \quad (7)$$

$$P_{bc} - P_b = R_5 Q_5^2; \quad (8)$$

$$P_{bc} - P_s = R_6 Q_6^2; \quad (9)$$

$$Q_0 = Q_5 + Q_4 + Q_6; \quad (10)$$

$$Q_e = Q_5 + Q_2 - Q_1 + Q_e; \quad (11)$$

$$Q_3 = Q_s + Q_6 + Q_7 + Q_1 - Q_2; \quad (12)$$

$$Q_f = Q_0 - Q_4; \quad (13)$$

$$Q_8 = Q_3 - Q_7; \quad (14)$$

$$Q_a = Q_8 + Q_c. \quad (15)$$

In addition for conventions used for combined equations (12)–(24) [4], the following conventions are introduced here:

$P_c$  is absolute pressure in the outer chamber of the upper (receiving) conveyor (Pa);

$P_{bc}, P_y$  are absolute pressures in the buffer chamber of the loading chute and in the inner chamber of the upper conveyor cowl (Pa);

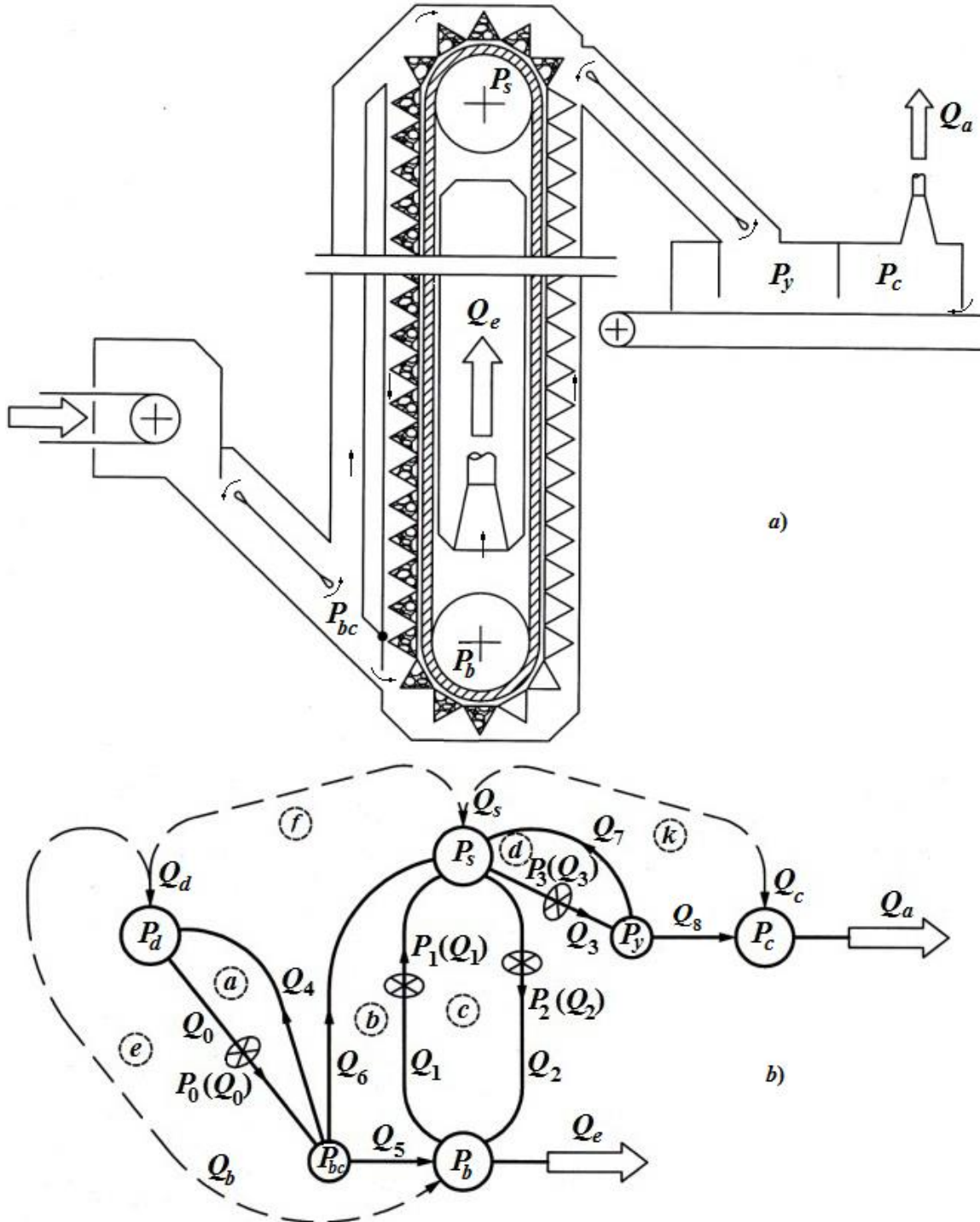
$Q_4, Q_6, Q_7$  are flow rates of air circulating in bypass ducts ( $\text{m}^3/\text{s}$ );

$Q_5, Q_8$  are flow rates of air coming in respectively from the buffer chamber into the bucket elevator boot enclosure and from the inner chamber into the outer chamber of upper conveyor cowl ( $\text{m}^3/\text{s}$ );

$R_4, R_6, R_7$  are aerodynamic properties of the respective bypass ducts ( $\text{Pa}/(\text{m}^3/\text{s})^2$ ) determined by their LRCs and cross-sectional areas:

$$R_4 = \rho \zeta_4 / (2S_4^2); \quad R_6 = \rho \zeta_6 / (2S_6^2); \quad R_7 = \rho \zeta_7 / (2S_7^2);$$

$\zeta_4, \zeta_6, \zeta_7$  are LRCs of the respective bypass ducts referenced to dynamic heads in their cross-sections;  $S_4, S_6, S_7$  are cross-sectional areas of the respective ducts ( $m^2$ ).



**Figure 1:** Aspiration layout for elevator handling with a bypass connection (a) and its aerodynamic equivalent (b)

The foregoing translates into a total of 19 unknown combined equations (1)...(15) and (17), (18), (38) and (40) [4] with nineteen unknown variables in the general case. These include air flow rates in ducts  $Q_0, Q_1, \dots, Q_8$ , air flow rates in leakage areas of cowls  $Q_s, Q_d, Q_b, Q_c$ , air flow rates in unspirated cowls  $P_s$  and  $P_d$ , pressures within recirculating flow separators  $P_{bc}$  and  $P_y$ , and flow rates of aspirated air  $Q_e$  and  $Q_a$ .

The number of equations may be reduced by applying the law for pressure losses in loops of complex ventilating systems as known from the aerology of mining. Let's write down the corresponding equations:

For the loop  $a$ :

$$P_0(Q_0) = R_0 Q_0^2 + R_4 Q_4^2; \quad (16)$$

For the loop  $b$ :

$$P_1(Q_1) = R_1 Q_1^2 + R_5 Q_5^2 - R_6 Q_6^2; \quad (17)$$

For the loop  $c$ :

$$P_1(Q_1) + P_2(Q_2) = R_1 Q_1^2 + R_2 Q_2^2; \quad (18)$$

For the loop  $d$ :

$$P_3(Q_3) = R_3 Q_3^2 + R_7 Q_7^2; \quad (19)$$

For the loop  $e^1$ :

$$P_0(Q_0) = R_0 Q_0^2 + R_5 Q_5^2 - R_s Q_s^2 + R_d (Q_0 - Q_4)^2; \quad (20)$$

For the loop  $f$ :

$$-R_s Q_s^2 + R_6 Q_6^2 + R_d (Q_0 - Q_4)^2 - R_4 Q_4^2 = 0; \quad (21)$$

For the loop  $k$ :

$$R_c Q_c^2 = R_8 Q_8^2 + R_s Q_s^2 - R_7 Q_7^2. \quad (22)$$

The ten unknown variables ( $Q_0, Q_1, \dots, Q_8, Q_s$ ) are represented with ten equations (16...22), (10), (14) and (12).

These combined non-linear equations will be solved iteratively. Specifically, we'll proceed from a set negative pressure in the unspirated cowl of elevator head (which would be equivalent to setting the initial value of  $Q_s$  due to (39)) [4]. For example, let this negative pressure be  $h$  ( $h_1 = 0$  or  $h_1 = h_c$  may be posited for the first approximation). Proceeding from these premises we'll determine air flow rates in ducts  $Q_0(h_i), Q_1(h_i), Q_2(h_i), \dots, Q_8(h_i)$  as functions of  $h_i$ . The next step is refining the negative pressure value:

$$s_i = R_s |Q_s(h_i)| Q_s(h_i), \quad (23)$$

where

$$Q_s(h_i) = Q_2(h_i) - Q_1(h_i) + Q_3(h_i) - Q_6(h_i) - Q_7(h_i).$$

The computation process repeats with a new value of  $h_{i+1}$ .

Computation can be facilitated if the following is posited for  $i+1$ -th approximation:

---

<sup>1</sup> Loops  $e, f, k$  are fictitious. They connect airflows in ducts by terminating them in the atmosphere of the room through leakage areas in cowls (these links are shown with dotted "ducts" in Fig. 1)

$$h_{i+1} = 0.5(h_i + s_i).$$

Computation stops as soon as the inequality is met:

$$|s_i - h_i| \leq E, \quad (24)$$

where  $E$  is the accepted precision ( $E \approx 10^{-2}$ ).

Now let's derive computation formulas for  $i$ -th approximations of air flow rates in ducts:  $Q_0(h_i), Q_1(h_i), \dots, Q_8(h_i)$ .

We'll begin with considering upper ducts adjacent to the cowl of bucket elevator "head". Equation (19) gives:

$$f_7 = Q_7(h_i) = \frac{L_3(Q_3(h_i))}{\sqrt{R_7 |L_3(Q_3(h_i))|}}, \quad (25)$$

where

$$L_3(Q_3(h_i)) = P_3(Q_3(h_i)) - R_3 |Q_3(h_i)| (Q_3(h_i)). \quad (26)$$

In view of the connection between negative pressure in the cowl and air flow rates in leakage area of this cowl, equation (22) will appear as:

$$-h_i + h_k = R_8 [Q_8(h_i)]^2 - R_7 |Q_7(h_i)| (Q_7(h_i)),$$

whence we can find

$$Q_8(h_i) = \frac{L_9}{\sqrt{R_8 |L_9|}}, \quad (27)$$

where

$$f_9 = L_9 = h_k - h_i + R_7 f_7(Q_3(h_i)) |f_7(Q_3(h_i))|. \quad (28)$$

(14) enables us to put forth the following equation with a single unknown variable  $Q_3(h_i)$ :

$$f_{10} = Q_3(h_i) - Q_8(Q_3(h_i)) - Q_7(Q_3(h_i)) = 0, \quad (29)$$

which can be solved using bisection. As soon as  $(Q_3(h_i))$  is found, formula (25) can be used to determine  $Q_7(h_i)$  and formula (27) can be used for  $Q_8(h_i)$ .

Let's now move on to the lower assembly (bucket elevator boot cowl). For the sake of clarity we'll omit the argument of air flow rate functions. Equation (20) in view of the connection between negative pressure and air flow rate in leakage areas of the elevator boot cowl will appear as:

$$h_b + L_0(Q_0) = R_5 Q_5^2 + R_d (Q_0 - Q_4)^2,$$

whence

$$f_5 = Q_5 = f_{15} / \sqrt{|f_{15}|}, \quad (30)$$

with the following functions introduced for a more convenient notation:

$$f_{15} = L_{15} = \frac{h_b + L_0(Q_0)}{R_d} - R_d (Q_0 - Q_4)^2, \quad (31)$$

$$f_0 = L_0(Q_0) = P_0(Q_0) - R_0 Q_0 |Q_0|. \quad (32)$$

Equation (16) results in:

$$f_4 = Q_4 = \frac{L_0(Q_0)}{\sqrt{R_4 |L_0(Q_0)|}}. \quad (33)$$

In order to resolve  $Q_6$  as a function  $Q_0$ , we'll use equation (21) which will be written as:

$$h_i - R_d(Q_0 - Q_4)|Q_0 - Q_4| + R_4 Q_4 |Q_4| = R_6 Q_6 |Q_6|$$

or

$$L_{11} = R_6 Q_6 |Q_6|, \quad (34)$$

where

$$L_{11} = f_{11} = h_i - R_d(Q_0 - Q_4)|Q_0 - Q_4| + R_4 Q_4 |Q_4|,$$

whence:

$$f_6 = Q_6 = \frac{L_{11}}{\sqrt{R_6 |L_{11}|}}. \quad (35)$$

Substitution of (30), (33) and (35) into the air balance equation (10) results in the following functional equation for determining  $Q_0$ :

$$f_{12} = Q_0 - Q_4(Q_0) - Q_5(Q_0) - Q_6(Q_0) = 0. \quad (36)$$

After determining  $Q_0(h_i)$  and substituting it into equations (30), (33) and (35), flow rates  $Q_4(h_i)$ ,  $Q_5(h_i)$  and  $Q_6(h_i)$  will become known.

In order to determine the remaining unknown variables  $Q_1$  and  $Q_2$ , equations (46)...(48) and (27)...(28) [3] can be used.

The resolved values of  $Q_1(h_i)$ ,  $Q_2(h_i)$ ,  $Q_3(h_i)$ ,  $Q_6(h_i)$  and  $Q_7(h_i)$  are substituted into (23) in order to determine the next iterative value of negative pressure.

The iterative process completes as soon as the condition (24) is met. A flowchart of the algorithm described above is shown in Fig. 2.

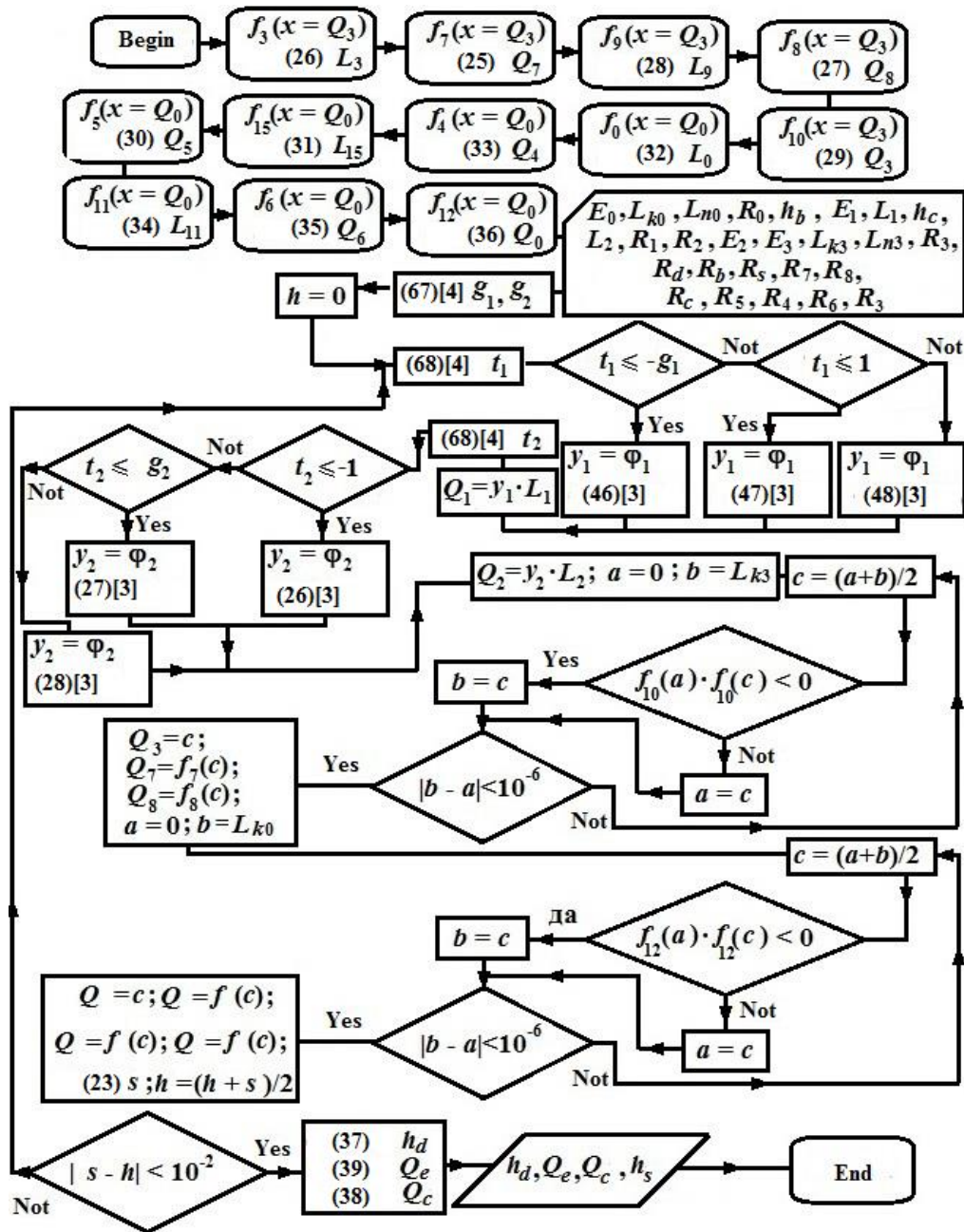
Computed flow rates of  $Q_0...Q_8$ , in addition to determining negative pressures in unspirated cowls of elevator head ( $h$ ) and in the feeder drive drum cowl,

$$h_d = R_d(Q_0 - Q_4)|Q_0 - Q_4|, \quad (37)$$

enable the required aspiration volumes to be computed as well.

$$Q_a = Q_8 + \sqrt{\frac{h_c}{R_c}}, \quad (38)$$

$$Q_e = Q_5 + Q_2 - Q_1 + \sqrt{\frac{h_b}{R_b}}. \quad (39)$$



**Figure 2:** Flowchart of the algorithm for computing air flow rates in ducts  $Q_0, Q_1 \dots Q_8$  and aspiration volumes  $Q_b$  and  $Q_c$  of a grain-handling elevator unit equipped with bypass connections:

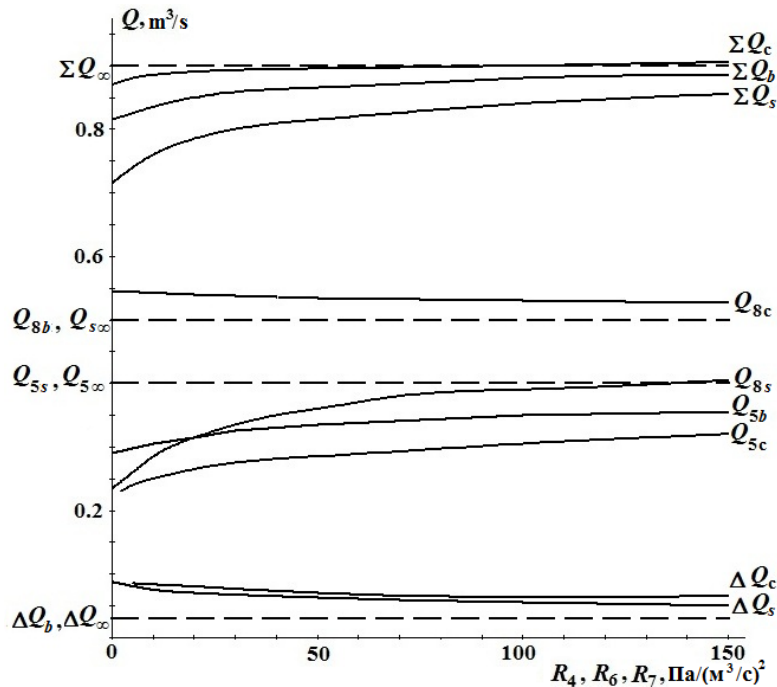
$$\begin{aligned}
 E_0 &= 4\text{Pa} / (\text{m}^3 / \text{s})^3; L_{k0} = 1.6\text{m}^3 / \text{s}; L_{n0} = 1\text{m}^3 / \text{s}; h_b = 5\text{Pa}; R_d = 10\text{Pa} / (\text{m}^3 / \text{s})^2; \\
 E_1 &= 200\text{Pa} / (\text{m}^3 / \text{s})^3; E_2 = 400\text{Pa} / (\text{m}^3 / \text{s})^3; R_1 = 21\text{Pa} / (\text{m}^3 / \text{s})^2; R_2 = 22\text{Pa} / (\text{m}^3 / \text{s})^2; \\
 L_1 &= L_2 = 1\text{m}^3 / \text{s}; R_0 = 10\text{Pa} / (\text{m}^3 / \text{s})^2; R_5 = 50\text{Pa} / (\text{m}^3 / \text{s})^2; R_8 = 25\text{Pa} / (\text{m}^3 / \text{s})^2; \\
 R_3 &= 50\text{Pa} / (\text{m}^3 / \text{s})^2; R_8 = 50\text{Pa} / (\text{m}^3 / \text{s})^2; R_b = 36\text{Pa} / (\text{m}^3 / \text{s})^2; E_3 = 5\text{Pa} / (\text{m}^3 / \text{s})^3; \\
 L_{k3} &= 2\text{m}^3 / \text{s}; L_{n3} = 0.5\text{m}^3 / \text{s}; h_c = 5\text{Pa}; R_c = 40\text{Pa} / (\text{m}^3 / \text{s})^2.
 \end{aligned}$$

The role of bypass connections can be evaluated by comparing the current values of  $Q_5, Q_8$  and  $\Delta Q$  with respective values of  $Q_{5\infty}, Q_{8\infty}$  and  $\Delta Q_\infty$  for an aspiration system without bypass connections. It would be best to choose a “standard” case of elevator facility design for this study. We’ll be using the previously considered example of elevator handling facility [4] that will be supplemented generally with three bypass channels by analogy with Fig. 1a. The following values will serve as constant parameters describing this handling facility.

Aerodynamic performance indices of bypass ducts  $R_4, R_6$  and  $R_7$  within the range of  $0.5 \dots 150 \text{ Pa}/(\text{m}^3/\text{s})^2$  will serve as variables. These values become fixed at  $10^9 \text{ Pa}/(\text{m}^3/\text{s})^2$  when the respective bypass duct is closed or disconnected. For example, if  $R_4 = R_6 = R_7 = 10^9$ , then air flow rates in bypass ducts will be  $Q_4 = Q_6 = Q_7 = 0$  i.e. bypass ducts are disconnected. Calculated values are presented on Fig. 3, 4 and 5. On these plots, air flow rates corresponding to the unbypassed case are designated with a subscript  $\infty$  and their changes are plotted using straight horizontal dotted lines. Another instance of a fixed aerodynamic performance index of bypass ducts occurs at  $25 \text{ Pa}/(\text{m}^3/\text{s})^2$ . For example, Fig. 3 indicates variations in air flow rates  $Q_5, Q_8, \Delta Q$  and their sum total  $\sum Q$  for three possible bypass layouts:

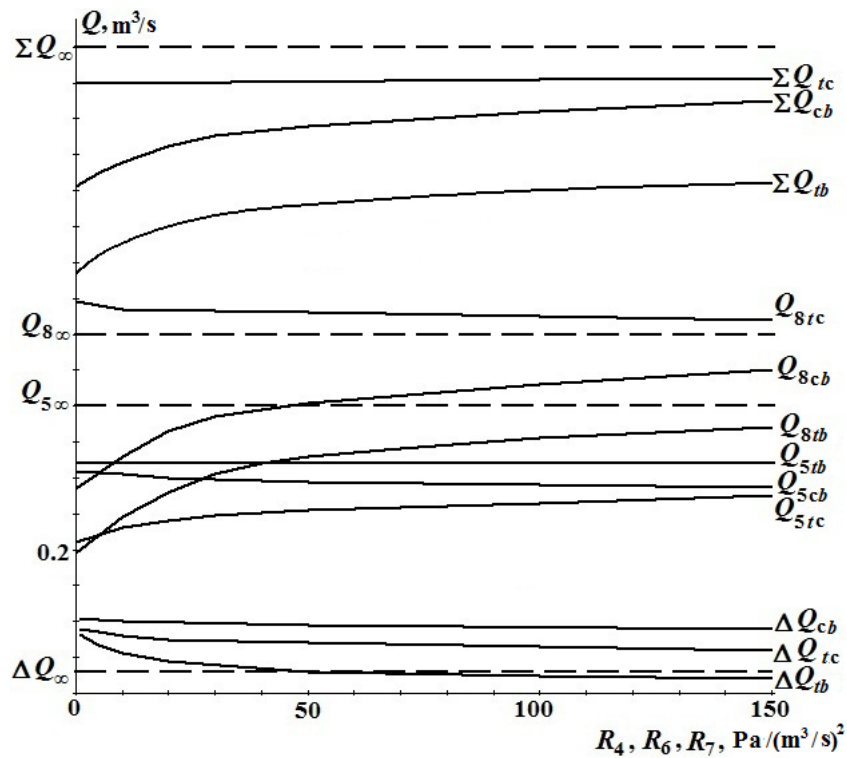
*Case #1:* Only a bottom bypass duct is provided (on the loading chute); its aerodynamic performance varies  $0.5 \leq R_4 \leq 150$  while other bypass ducts are absent (their aerodynamic performance converges toward  $\infty$  or, more precisely, is  $R_6 = R_7 = 10^9$ );

*Case #2:* Only the middle bypass duct (located on elevator enclosure) is arranged i.e.  $0.5 \leq R_6 \leq 150$  and  $R_4 = R_7 = 10^9$ ;

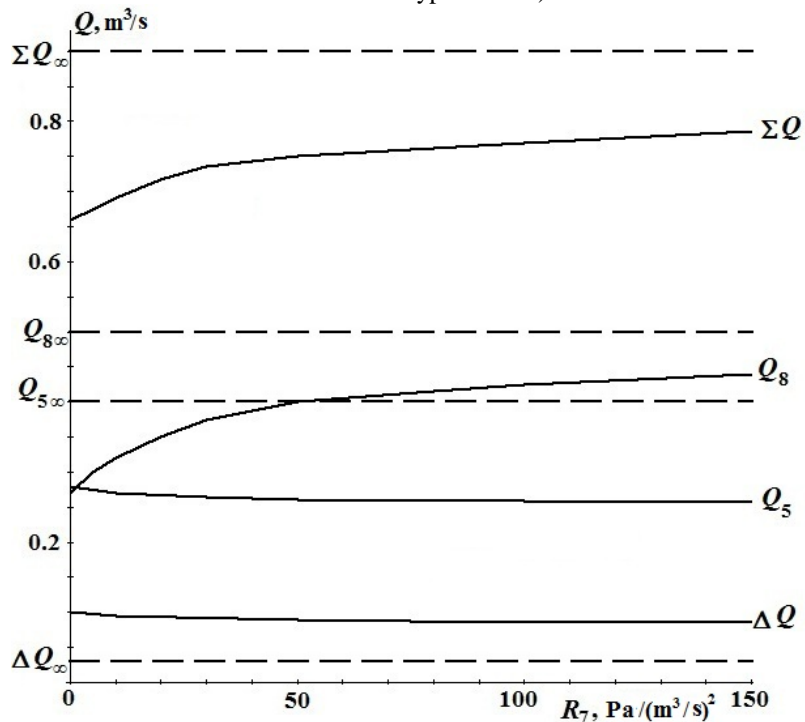


**Figure 3:** Air flow rates  $Q_5, Q_8, \Delta Q$  and  $\sum Q$  as functions of aerodynamic drag for an elevator equipped with a single bypass duct (H – lower, M – middle, B – upper,  $\infty$  – no bypass ducts)





**Figure 4:** Air flow rates  $Q_5$ ,  $Q_8$ ,  $\Delta Q$  and  $\Sigma Q$  as functions of aerodynamic resistance for an elevator equipped with two bypass ducts (HC – lower and medium, CB – medium and upper, HB – lower and upper,  $\infty$  – no bypass ducts)



**Figure 5:** Air flow rates  $Q_5$ ,  $Q_8$ ,  $\Delta Q$  and  $\Sigma Q$  as functions of aerodynamic drag  $R_7$  for an elevator equipped with three bypass ducts

Case 3: Only the upper bypass duct is provided (on the discharge chute) i.e.  $0.5 \leq R_7 \leq 150$  and  $R_4 = R_6 = 10^9$  (this case is illustrated in Fig. 3).

Fig. 4 plots air flow rates for three possible design layouts of bypass ducts: case 1 – lower and middle bypass ducts are installed so that  $R_4 = 25 \frac{\text{Pa}}{(\text{m}^3/\text{s})^2}$ ,  $0.5 \frac{\text{Pa}}{(\text{m}^3/\text{s})^2} \leq R_6 \leq 150 \frac{\text{Pa}}{(\text{m}^3/\text{s})^2}$ ,  $R_7 = 10^9 \frac{\text{Pa}}{(\text{m}^3/\text{s})^2}$ ; case 2 – middle and upper bypass ducts are installed so that  $R_4 = 10^9 \frac{\text{Pa}}{(\text{m}^3/\text{s})^2}$ ,  $R_6 = 10^9 \frac{\text{Pa}}{(\text{m}^3/\text{s})^2}$ ,  $0.5 \frac{\text{Pa}}{(\text{m}^3/\text{s})^2} \leq R_7 \leq 150 \frac{\text{Pa}}{(\text{m}^3/\text{s})^2}$ ; case 3 – lower and upper bypass ducts are installed, so that  $R_4 = R_6 = 25 \frac{\text{Pa}}{(\text{m}^3/\text{s})^2}$  and  $0.5 \frac{\text{Pa}}{(\text{m}^3/\text{s})^2} \leq R_7 \leq 150 \frac{\text{Pa}}{(\text{m}^3/\text{s})^2}$ .

Fig. 5 contains plots of air flow rates for the only possible configuration with three bypass ducts: lower, medium and upper, so that  $R_4 = 25 \frac{\text{Pa}}{(\text{m}^3/\text{s})^2}$ ,  $R_6 = 25 \frac{\text{Pa}}{(\text{m}^3/\text{s})^2}$ ,  $0.5 \frac{\text{Pa}}{(\text{m}^3/\text{s})^2} \leq R_7 \leq 150 \frac{\text{Pa}}{(\text{m}^3/\text{s})^2}$ .

As the plots illustrate, installation of bypass ducts noticeably decreases the total amount of air entering through leakage areas of unspirated cowls in elevator feeder and head:

$$\sum Q = Q_5 + Q_8 + \Delta Q,$$

where  $\Delta Q = Q_2 - Q_1$ .

So, with a single bypass duct installed, installation of the upper bypass duct (Fig. 3) provides the greatest effect: at  $R_7 = 25 \frac{\text{Pa}}{(\text{m}^3/\text{s})^2}$  ( $R_6 = R_7 = 10^9$ ) the total volume of air

$$\sum Q_s = \frac{0.79}{0.9} \sum Q_\infty = 0.88 \sum Q_\infty,$$

that is, 1.14 times smaller than without bypass ducts installed. An even greater effect is achieved when the elevator is equipped with two bypass connections at the top and at the bottom (Fig. 3): at  $R_4 = 25 \frac{\text{Pa}}{(\text{m}^3/\text{s})^2}$ ,  $R_6 = 10^9 \frac{\text{Pa}}{(\text{m}^3/\text{s})^2}$  and  $R_7 = 25 \frac{\text{Pa}}{(\text{m}^3/\text{s})^2}$  the total volume of air is

$$\sum Q_{tb} = \frac{0.66}{0.9} \sum Q_\infty = 0.73 \sum Q_\infty,$$

i.e. 1.37 times less than for the case of aspiration without bypass connections installed.

It would be unwise to install three bypass connections in this case, as with

$$R_4 = R_6 = R_7 = 25 \frac{\text{Pa}}{(\text{m}^3/\text{s})^2},$$

$$\sum Q_{\text{tbm}} = \frac{0.73}{0.9} \sum Q_{\infty} = 0.81 \sum Q_{\infty},$$

i.e. efficiency would be lower than with two (upper and lower) bypass connections. This happens because cross-flows of air from the upper cowl (at the elevator head) into the lower cowl (elevator boot cowl) increases as negative pressure in the upper cowl is reduced to 2.1 Pa ( $h_s = 5.6$  Pa for the case of upper and lower bypass ducts). Meanwhile,  $\Delta Q$  increases from 0.046 m<sup>3</sup>/s with two bypass ducts to 0.093 m<sup>3</sup>/s with three bypass ducts.

With regard to aspiration volumes the effect of bypassing appears less prominent. For example, in the case of upper and lower bypass ducts in the example considered,

$$Q_a = \sum Q_{\text{tb}} + Q_b + Q_c = 0.66 + \sqrt{\frac{5}{36}} + \sqrt{\frac{5}{40}} = 0.66 + 0.73 = 1.39 \text{ m}^3/\text{s},$$

while, absent any bypass ducts,

$$Q_{a\infty} = \sum Q_{\infty} + Q_b + Q_c = 0.9 + 0.73 = 1.63 \text{ m}^3/\text{s},$$

i.e. 17% higher.

It should be noted that values indicated may be higher. A specially developed computation methodology and software enable to evaluate the effect in each specific case on the design stage, making it possible to devise efficient layouts of aspiration [6-10] and bypassing for elevator handling of grain.

### 3 CONCLUSIONS

- volumes in elevator handling facilities by maintaining a smaller negative pressure inside un aspirated cowls of the elevator feeder and head. Airflows can be quantitatively decomposed using combined equations (16)-(22) describing pressure losses in loops of a proposed aerodynamic equivalent for the assembly (Fig. 1b). These combined non-linear equations have been solved numerically using a specially developed algorithm (Fig. 2) based upon joint application of iterative and bisection procedures.
- Analysis of the findings for a “standard” elevator (Fig. 3, 4 and 5) indicates that reduction in flow rates of air ( $\sum Q$ ) entering through leakage areas of un aspirated cowls is maximized when two bypass connections are installed: the lower one, connecting feeder cowl with a buffer chamber upstream of elevator boot cowl, and the upper one, connecting elevator head cowl with the inner chamber of a double-walled cowl of the upper (receiving) conveyor. The total flow rate  $\sum Q$  in the case reviewed was 1.37 times lower than  $\sum Q_{\infty}$  (a corresponding aspiration case with identical process and design parameters of the assembly, but with no bypass ducts).
- The effect cited may differ from the actual effect in every particular case. The computer program developed for the purpose can be used to provide a design-stage estimate.

## Funding

This study would not have been possible without a grant from the Russian Science Foundation (Project No. 18-79-10025).

## REFERENCES

- [1] Averkova, O.A., Logachev, I.N., Logachev, K.I. Peculiarities of air entrainment with a loose material flow at the variable aerodynamic resistance of falling particles. *VII International Conference on Computational Methods for Coupled Problems in Science and Engineering (COUPLED PROBLEMS 2017)* (2017) 636-644.
- [2] Averkova, O.A., Logachev, I.N., Logachev, K.I. Ejecting properties of a bucket elevator. *V International Conference on Particle-based Methods. Fundamentals and Applications (PARTICLES 2017)*(2017) 45–56.
- [3] Averkova, O.A., Logachev, I.N., Logachev, K.I. Cross-flow of air through sealed elevator enclosures. *V International Conference on Particle-based Methods. Fundamentals and Applications (PARTICLES 2017)* (2017) 33–44.
- [4] Averkova, O.A., Logachev, I.N., Logachev, K.I., Uvarov, V.A. and Ziganshin, A.M. Features of the settlement scheme aspiration of elevator overloads. *6th European Conference on Computational Mechanics, 7th European Conference on Computational Fluid Dynamics (ECCM-ECFD 2018)* (2018): 2626-2638.
- [5] Averkova, O.A., Logachev, I.N., Logachev, K.I., Uvarov, V.A. and Ziganshin, A.M. Development of methods for reducing the volume of aspiration during overloads of granular materials by bucket elevators. *6th European Conference on Computational Mechanics, 7th European Conference on Computational Fluid Dynamics (ECCM-ECFD 2018)* (2018): 2638-2649.
- [6] Sidelnikova, O.P., Evtushenko, A.I., Azarov, V.N. Modern problems of Russian enterprises with respect to occupational and industrial safety. *2018 IOP Conf. Ser.: Mater. Sci. Eng.* 451 012187 <https://doi.org/10.1088/1757-899X/451/1/012187>
- [7] Kozlovtseva, E.Yu., Azarov, V.N. and Stefanenko, I.V. Analysis of the dust particles distribution and ventilation as a way to improve indoor air quality. *2017 IOP Conf. Ser.: Earth Environ. Sci.* 90 012025 <https://doi.org/10.1088/1755-1315/90/1/012025>
- [8] Zaitsev, O.N, Stefanenko I.V. and Azarov V.N. Experimental speed study of twirled gas pipe with precessing vortex nuclei. *2018 IOP Conf. Ser.: Mater. Sci. Eng.* 451 012225 <https://doi.org/10.1088/1757-899X/451/1/012225>
- [9] I.N. Logachev and K.I. Logachev, *Industrial Air Quality And Ventilation: Controlling Dust Emissions*, 1th Edition, CRC Press, 2014.
- [10] Logachev I.N., Logachev K.I., Averkova O.A. *Local Exhaust Ventilation: Aerodynamic Processes and Calculations of Dust Emissions*. 1th Edition, CRC Press, 2015.